

# ***ECOLINE***

Four Page Newspaper Offset Press



**MANUGRAPH**  
Technology in Print

## A Versatile Single Width Single Circumference Four Page Press.

Manograph introduces its new four page Newspaper press ECOLINE for flexible newspaper printing. While featuring compactness in 2x1 concept with single level operating, it offers optimum output with the flexibility of single width presses to meet small & medium size volumes.

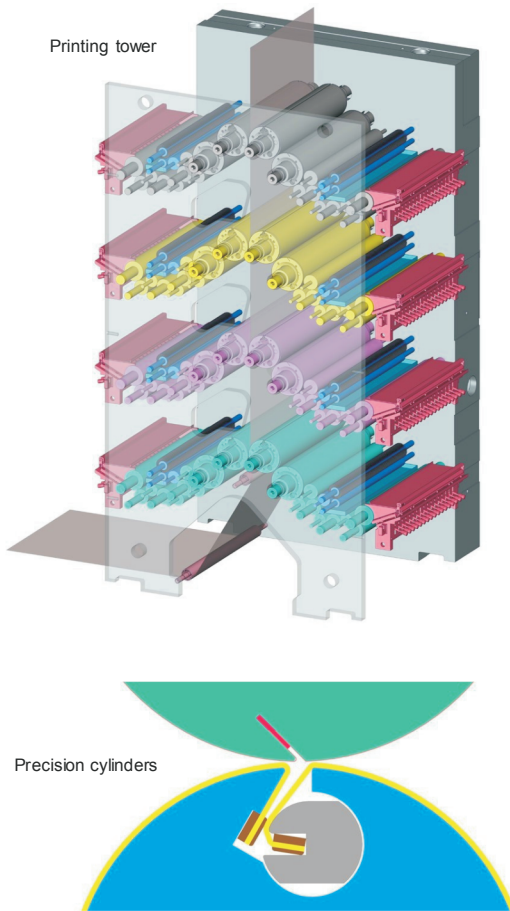

### AP3542 Flying Splicer

- Two arm Reel splicer capable to hold reel diameter of 1067 mm.
- Pneumatic shaft for reel holding.
- Manual reel alignment  $\pm 10$  mm.
- Belt acceleration for new reel.
- Dancing roller with precision electro-pneumatic braking system.
- Inline, 90° or Cellar placement.
- Mechanical/Hydraulic web trolley for reel loading.
- Reel loading and unloading from same side.
- Close loop Infeed system (optional).

The innovative concept of Printing Tower to offer 4x4 colour printing through single deck. Four printing stations are well aligned in a single wall structure, thus giving compactness resulting in single level operation, high print quality, better control on waste and less floor occupation.

### Tower Features at a glance

- Tower type modular construction with vertical web lead.
- Solid plate and blanket cylinders mounted on precision taper roller bearings (in ceased in bushes).
- Dynamically balanced solid steel cylinders with hard chrome plating.
- Micro-gap plate lock-up, toolless plate loading.
- Tennon type blanket locking system 4 Ply blanket.
- Precision class helical gears for cylinders.
- Swing down ink fountain for faster make ready.
- 8 rollers film type inking system with 2 form rollers.
- Brush dampening system.
- Manual lateral and circumferential registration system  $\pm 2$  mm.
- Shortest first to last nip distance.
- Single level operating.
- Web break detector at exit of Tower.
- Pneumatics for impression and roller on/off.
- Main drive decoupling arrangement.
- Motorized lubrication system.
- Overload protection system in Tower.
- HMI (Human Machine Interface) controls.
- Manual operated web lead system.
- PLC base control system.

### Optionals

- Reel Rod blanket locking system (4 Ply blanket).
- Motorised registration system.
- Washing device per ink train.
- Web severer at entry and exit of Tower.
- Spray dampening system.
- Manual web up system in Tower.
- Two web provision in Tower.
- UV attachment.

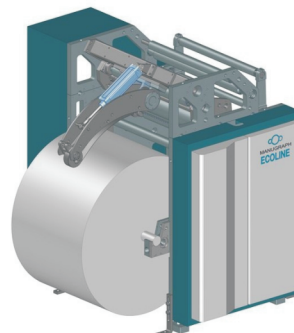

## F122 Folder

Ecoline comes with F122 Jaw Folder as a standard. Choices of Broadsheet, Tabloid & Quarter fold products are available. F122 can handle 6 webs to produce a 24 page broadsheet or a 48 page tabloid product. With the Quarter fold attachment, 32 page signatures can be produced. Option of balloon former is also available.

### Folder Features

- 24 page broadsheet | 48 page tabloid.
- Air cushioned 60° former.
- Variable drive for RTF.
- Lap adjustment facility.
- Diameter increment on folding cylinder.
- Shear pin in the folder drive line.
- Slitter mechanism for tabloid production.
- Batch counter.
- Optional attachments :
  - Quarter Fold
  - Upper Former
  - Longitudinal / cross perforation - 1/8 Fold
  - Motorized cut-off compensators

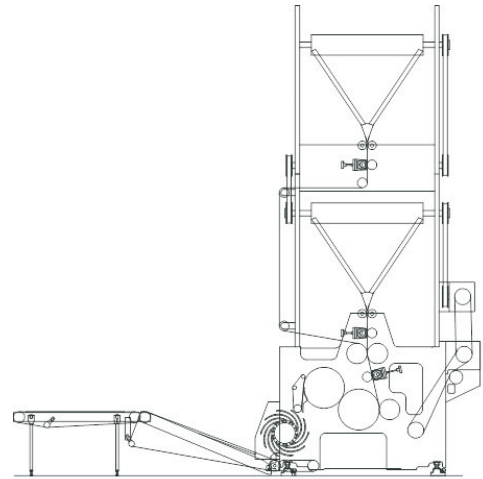

**F122 Folder**

### Electrical Features

Drive	AC Drive control
Print functions controls	Through Selector switch
Electrical Control theme	PLC base
Jam detection	Through Limit switch Web
Break detection	Through Sensor
Console	Mini Console cabinet

### Machine Configuration



## Specifications

Maximum Output (copies/h)	25,000	
Plate Cylinder rph	25,000	
Pages per web (broadsheet)	4	
Web width (mm)	700	915
Cut off lengths (mm)	533, 546	508, 578
Printing unit modules	Tower type	
Reel splicer	AP 3542 (42" Reel holding)	
Folder	F122 Jaw Folder	
Max. no. of webs	Up to 6 nos.	
Data management	PLC Based	
Drive	Shafted	
Tower height	2.7 meters.	
Accessories	- Plate Punching device - Plate Bending device - Web Trolley for Reel loading - Water Tank	

Note : Depending on customer needs Manugraph can also offer aggregates and features of other Manugraph productlines to meet specific demands.



### Manugraph India Ltd.

Sidhwa House, N.A. Sawant Marg, Colaba, Mumbai - 400 005  
Tel:- +91-22-2287 4815 / 4788 / 1191 / 0620 Fax:- +91-22-2281 0702  
Email: [sales@manugraph.com](mailto:sales@manugraph.com) [www.manugraph.com](http://www.manugraph.com)

*Ecoline is subject to continuous upgradation resulting from ongoing research and development and practical experiences gained. Therefore, in the interest of the customers we reserve the right to modify the specifications, features and technical data without notice. Only the specifications while confirming the order shall be binding.*

*Ecoline is a registered trademark of Manugraph India Ltd.*

Updated - April 2016